

CircuPool® SmartFlo®

Ultra-Efficient Variable Speed Pump - Installation and Operation Guide



Models: **USF1.0P USF1.7P USF2.0P USF3.0P**



SmartFlo Series VS Pump
Advanced Swimming Pool Circulation







2100-5A | R202411

TABLE OF CONTENTS

SAFETY INSTRUCTIONS	3
INTRODUCTION	5
GETTING STARTED	5
SYSTEM OVERVIEW	6
Features	6
INSTALLATION	7
Pump Configuration	7
Installation Location	8
Piping	8
Fittings and Valves	8
Electrical Requirements	8
Wiring Overview	9
CONTROL PANEL OVERVIEW	10
Keypad Navigation	10
OPERATING THE PUMP	11
Setting the Clock	11
Operation Overview	11
Using the Default Schedule	13
Speed 1 and Priming	13
Custom Schedules and Quick Clean	14
Speed Priorities	15
Operating the Pump While Running	15
Customizing Freeze Protection	15
MAINTENANCE	16
Routine Maintenance	16
Cleaning the Pump Strainer Basket	16
Winterizing	16
SERVICING	17
Electric Motor Care	17
Shaft Seal Replacement	17
Pump Disassembly	17
Pump Reassembly	18
Restart Instructions	18
TROUBLESHOOTING	19
Troubleshooting Chart	19
Errors and Alarms	20
REPLACEMENT PARTS	21
SPECIFICATIONS	22
Models USF1.0P, USF1.7P, USF2.0P, USF3.0P	22
WARRANTY	23

SAFETY INSTRUCTIONS

IMPORTANT SAFETY INSTRUCTIONS. Read and follow all instructions. Ensure all owners / operators of this equipment have access to these instructions. Save all instructions. When installing and using this electrical equipment, basic safety precautions should always be followed, including the following. Please consult manufacturer with any questions regarding this equipment.

	This is the safety alert symbol. When you see this symbol on your system or in this manual, look for one of the following signal words and be alert to the potential for personal injury or property damage:
	DANGER Warns about hazards that can cause death, serious personal injury, or major property damage if ignored.
	WARNING Warns about hazards that may cause death, serious personal injury, or major property damage if ignored.
	CAUTION Warns about hazards that may or can cause minor personal injury or property damage if ignored.
NOTE	Indicates special instructions not related to hazards.

Carefully read and follow all safety instructions in this manual and on equipment. Keep safety labels in good condition; replace if missing or damaged.

⚠ DANGER FAILURE TO FOLLOW ALL INSTRUCTIONS AND WARNINGS CAN RESULT IN SERIOUS BODILY INJURY OR DEATH. **THIS PUMP SHOULD BE INSTALLED AND SERVICED ONLY BY A QUALIFIED PERSON. INSTALLERS, POOL OPERATORS AND OWNERS MUST READ THESE WARNINGS AND ALL INSTRUCTIONS IN THE OWNER'S MANUAL BEFORE USING THIS PUMP. THESE WARNINGS AND THE OWNER'S MANUAL MUST BE LEFT WITH THE POOL OWNER.**

⚠ WARNING **RISK OF ELECTRICAL SHOCK.** Connect only to a branch circuit protected by a ground-fault circuit-interrupter (GFCI). Contact a qualified electrician if you cannot verify that the circuit is protected by a GFCI. This unit must be connected only to a supply circuit that is protected by a ground-fault circuit-interrupter (GFCI). Such a GFCI should be provided by the installer and should be tested on a routine basis. To test the GFCI, push the test button. The GFCI should interrupt power. Push the reset button. Power should be restored. If the GFCI fails to operate in this manner, the GFCI is defective. If the GFCI interrupts power to the pump without the test button being pushed, a ground current is flowing, indicating the possibility of an electric shock. Do not use this pump. Disconnect the pump and have the problem corrected by a qualified service representative before using.

⚠ WARNING Do not permit children to use this product. This appliance is not intended for use by persons of reduced physical, sensory or mental capabilities, or lack of experience and knowledge, unless they have been given supervision or instruction concerning the use of the appliance by a person responsible for their safety.

⚠ CAUTION This pump is for use with permanent swimming pools and may also be used with hot tubs and spas if so marked. Do not use with storable pools. A permanently-installed pool is constructed in or on the ground or in a building such that it cannot be readily disassembled for storage. A storable pool is constructed so that it is capable of being readily disassembled for storage and reassembled to its original integrity.

⚠ DANGER **SUCTION ENTRAPMENT HAZARD: STAY OFF THE MAIN DRAIN AND AWAY FROM ALL SUCTION OUTLETS!**

THIS PUMP PRODUCES HIGH LEVELS OF SUCTION AND CREATES A STRONG VACUUM AT THE MAIN DRAIN AT THE BOTTOM OF THE BODY OF WATER. THIS SUCTION IS SO STRONG THAT IT CAN TRAP ADULTS OR CHILDREN UNDER WATER IF THEY COME IN CLOSE PROXIMITY TO A DRAIN OR A LOOSE OR BROKEN DRAIN COVER OR GRATE.



THE USE OF UNAPPROVED COVERS OR ALLOWING USE OF THE POOL OR SPA WHEN COVERS ARE MISSING, CRACKED OR BROKEN CAN RESULT IN BODY OR LIMB ENTRAPMENT, HAIR ENTANGLEMENT, BODY ENTRAPMENT, EVISCERATION AND/OR DEATH.

The suction at a drain or outlet can cause the hazards including but not limited to the following: (i) **Limb Entrapment:** When a limb is sucked or inserted into an opening resulting in a mechanical bind or swelling. This hazard is present when a drain cover is missing, broken, loose, cracked or not properly secured. (ii) **Hair Entanglement:** When the hair tangles or knots in the drain cover, trapping the swimmer underwater. This hazard is present when the flow rating of the cover is too small for the pump or pumps. (iii) **Body Entrapment:** When a portion of the body is held against the drain cover trapping the swimmer underwater. This hazard is present when the drain cover is missing, broken or the cover flow rating is not high enough for the pump or pumps. (iv) **Evisceration/Disembowelment:** When a person sits on an open pool (particularly a child wading pool) or spa outlet and suction is applied directly to the intestines, causing severe intestinal damage. This hazard is present when the drain cover is missing, loose, cracked, or not properly secured. (v) **Mechanical Entrapment:** When jewelry, swimsuit, hair decorations, finger, toe or knuckle is caught in an opening of an outlet or drain cover. This hazard is present when the drain cover is missing, broken, loose, cracked, or not properly secured.

NOTE: ALL SUCTION PLUMBING MUST BE INSTALLED IN ACCORDANCE WITH THE LATEST NATIONAL AND LOCAL CODES, STANDARDS AND GUIDELINES.

⚠ WARNING MINIMIZE THE RISK OF INJURY DUE TO SUCTION ENTRAPMENT HAZARD, including but not limited to the following: (i) A properly installed and secured ANSI/ASME A112.19.8 approved anti-entrapment suction cover must be used for each drain. (ii) Each suction cover must be installed at least three (3') feet apart, as measured from the nearest point to nearest point. (iii) Regularly inspect all covers for cracks, damage and advanced weathering. (iv) If a cover becomes loose, cracked, damaged, broken or is missing, replace with an appropriate certified cover. (v) Replace drain covers as necessary. Drain covers deteriorate over time due to exposure to sunlight and weather. (vi) Avoid getting hair, limbs or body in close proximity to any suction cover, pool drain or outlet. (vii) Disable suction outlets or reconfigure into return inlets.

⚠ WARNING A clearly labeled emergency shut-off switch for the pump must be in an easily accessible, obvious place. Make sure users know where it is and how to use it in case of emergency.

CAUTION General Warnings: • The pump is not submersible.

- Never open the inside of the drive motor enclosure. There is a capacitor bank that holds a 230 VAC charge even when there is no power to the unit.
- The pump is capable of high flow rates; use caution when installing and programming to limit pumps performance potential with old or questionable equipment.
- Code requirements for electrical connection differ from country to country, state to state, as well as local municipalities. Install equipment in accordance with the National Electrical Code and all applicable local codes and ordinances.
- Do not install in tightly enclosed areas that will not allow adequate motor ventilation

The Virginia Graeme Baker (VGB) Pool and Spa Safety Act creates new requirements for owners and operators of commercial swimming pools and spas.

Commercial pools or spas constructed on or after December 19, 2008, shall utilize:

(A) A multiple main drain system without isolation capability with suction outlet covers that meet ASME/ANSI A112.19.8a Suction Fittings for Use in Swimming Pools, Wading Pools, Spas, and Hot Tubs and either:

- (i) A safety vacuum release system (SVRS) meeting ASME/ANSI A112.19.17 Manufactured Safety Vacuum Release systems (SVRS) for Residential and Commercial Swimming Pool, Spa, Hot Tub, and Wading Pool Suction Systems and/or ASTM F2387 Standard Specification for Manufactured Safety Vacuum Release Systems (SVRS) for Swimming pools, Spas and Hot Tubs or
- (ii) A properly designed and tested suction-limiting vent system or
- (iii) An automatic pump shut-off system.

Commercial pools and spas constructed prior to December 19, 2008, with a single submerged suction outlet shall use a suction outlet cover that meets ASME/ANSI A112.19.8a and either:

- (A) A SVRS meeting ASME/ANSI A112.19.17 and/or ASTM F2387, or
- (B) A properly designed and tested suction-limiting vent system, or
- (C) An automatic pump shut-off system, or
- (D) Disabled submerged outlets, or
- (E) Suction outlets shall be reconfigured into return inlets.

- Before servicing the pump; switch OFF power to the pump by disconnecting the main circuit to the pump.
- Do not store chemicals near your pool equipment. Chemical fumes or spills can corrode and weaken equipment and structures.
- Do not subject pool filter and/or pump to piping system pressurization tests.
- **Do not start pump dry. Running pump dry will cause severe damage.** Keep all suction components clear of debris, leaves dirt, hair, paper, or other of obstructions that result in increased potential for suction entrapment and impeded flow through pump. **Running the pump in this manner will void the warranty.**

CAUTION For Installation of Electrical Controls at Equipment Pad (ON/OFF Switches, Timers and Automation Load Center)



Install all electrical controls at equipment pad, such as on/off switches, timers, and control systems, etc. to allow the operation (startup, shut-down, or servicing) of any pump or filter so the user does not place any portion of his/her body over or near the pump strainer lid, filter lid or valve closures. This installation should allow the user enough space to stand clear of the filter and pump during system start-up, shut down or servicing of the system filter.

DANGER HAZARDOUS PRESSURE: STAND CLEAR OF PUMP AND FILTER DURING START UP



Circulation systems operate under high pressure. When any part of the circulating system (i.e. locking ring, pump, filter, valves, etc.) is serviced, air can enter the system and become pressurized. Pressurized air can cause the pump housing cover, filter lid, and valves to violently separate which can result in severe personal injury or death. Filter tank lid and strainer cover must be properly secured to prevent violent separation. Stand clear of all circulation system equipment when turning on or starting up pump.

Before servicing equipment, make note of the filter pressure. Be sure that all controls are set to ensure the system cannot inadvertently start during service. Turn off all power to the pump. **IMPORTANT: Place filter manual air relief valve in the open position and wait for all pressure in the system to be relieved.**

(continued from above) Before starting the system, fully open the manual air relief valve and place all system valves in the "open" position to allow water to flow freely from the tank and back to the tank. Stand clear of all equipment and start the pump.

IMPORTANT: Do not close filter manual air relief valve until all pressure has been discharged from the valve and a steady stream of water appears. Observe filter pressure gauge and be sure it is not higher than the pre-service condition.

General Installation Information

- All work must be performed by a qualified individual, and must conform to all national, state, and local codes.
- Install to provide drainage of compartment for electrical components.
- These instructions contain information for a variety of pump models and therefore some instructions may not apply to a specific model. All models are intended for use in swimming pool applications. The pump will function correctly only if it is properly sized to the specific application and properly installed.

WARNING If existing electrical wires or suction components are found to be damaged, broken, cracked, missing, or unsecured, replace or replace immediately.

WARNING This pump is capable of high flow rates. Incorrectly installed equipment may fail, causing severe injury or property damage. Improperly configured or programmed pump controls can cause damage to the existing pool equipment and plumbing especially if old, questionable, or not properly matched to pump. Pumps improperly sized or installed or used in applications other than for which the pump was intended can result in severe personal injury or death. These risks may include but not be limited to electric shock, fire, flooding, suction entrapment or severe injury or property damage caused by a structural failure of the pump or other system component.

WARNING The pump can produce high levels of suction within the suction side of the plumbing system. These high levels of suction can pose a risk if a person comes within the close proximity of the suction openings. A person can be seriously injured by this high level of vacuum or may become trapped and drown. It is absolutely critical that the suction plumbing be installed in accordance with the latest national and local codes for swimming pools.

CAUTION Safe operation of other pool equipment, such as a salt chlorination system, often requires a minimum water flow rate. Verify that you get sufficient water flow when pump is set to low RPM speeds. Never operate a salt chlorinator when the flow of water is not present, restricted, or insufficient. If water flow to the salt chlorinator is restricted or insufficient, a build-up of flammable gases will result in hazardous conditions.

CAUTION Proper pool chemistry must be maintained at all times.

WARNING Always disconnect power to the pool pump at the circuit breaker before servicing the pump.



SmartFlo Series Owner's Manual

INTRODUCTION

Congratulations on your recent purchase of a **CircuPool SmartFlo Series** Variable Speed Pump. The SmartFlo Series uses a whisper quiet TEFC permanent magnet motor for ultra energy-efficient operation and heavy-duty construction to provide a rugged and tested design perfect for in-ground or permanently installed above-ground pools. Its adjustable & programmable motor allows you to select the optimal motor speeds and run times for your pool's needs. Please take a moment to read through the entire manual before installing your new unit. Your pump must be installed and operated as specified.

GETTING STARTED

READ ENTIRE MANUAL FIRST - To ensure consistent & reliable operation, the pool and equipment must be used and maintained as specified. Most issues are easily avoidable with correct maintenance.

Before installation or operation, please take the time to read this entire manual, compare package contents with the parts list, and gather tools required. Improper installation may void the warranty and create unnecessary hazards. This manual contains instructions to help ensure that your installation meets the recommended standards. Spending the time to understand your system and its functions will assure successful, trouble-free operation.

As with any electrical device, it is very important that the installation and service of this equipment be performed by a qualified person with the skills and experience required to do it safely and correctly. Improper installation or service can result in severe electrical shock to the installer or user of the equipment or pool. Please choose your installer with great care! Be sure to familiarize yourself with the pool chemistry requirements and maintenance procedures.

Please visit www.circupool.com/help for more information, tips, and troubleshooting assistance.



This pump is for use with 230V RMS nominal, and in pool pump applications ONLY. Connection to the wrong voltage, or use in other application may cause damage to equipment or personal injury.

SMARTFLO SYSTEM OVERVIEW

Features:

- Extremely quiet operation.
- Super-duty totally-enclosed fan-cooled (TEFC) permanent magnet motor, for long life and premium energy efficiency.
- Energy-Star Rated and ETL Listed
- NEMA Type 3 Environmental Rating
- Unionized fittings for simple replacement. Compatible with 2.5", 2", 1.5" ID Sch.40 Pipe.
- Self-priming for quick, easy startup.
- Tool-free strainer cover for easy cleaning and maintenance. See-through lid permits easy inspection of strainer basket.
- Simple user interface, IPX6 certified UV and rain-proof enclosure.
- Onboard time of day schedule.
- Adjustable priming mode.
- Programmable quick clean mode.
- Diagnostic alarm display & retention.
- Active power factor correction.
- Accepts 230V nominal, 50/60Hz input power.
- Auto power limiting protection circuit.
- Onboard clock retention for power outages.

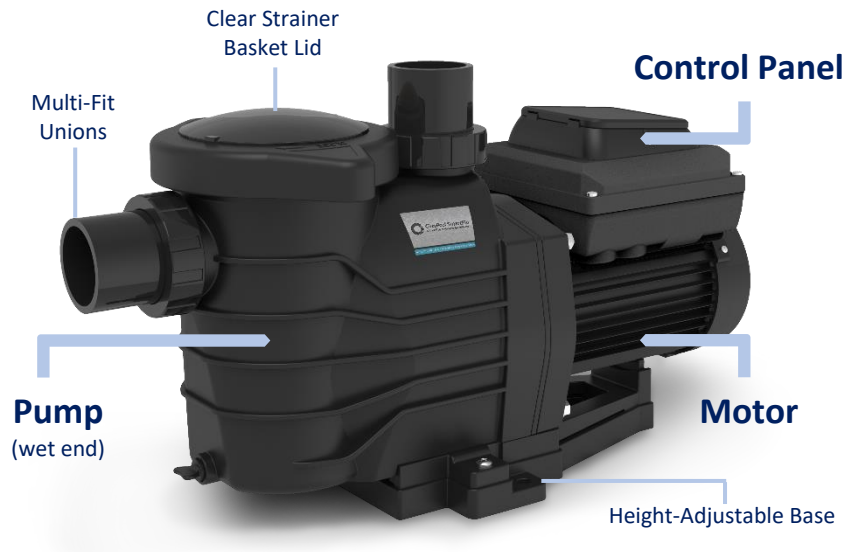

Also Included: Union gaskets, Reducer Bushings

Your SmartFlo Pump

The SmartFlo VS swimming pool pump uses a premium efficiency variable speed motor, durable pump body, and advanced hydraulic engineering, allowing it to provide highly efficient pool circulation. The SmartFlo's user-friendly controls are programmable and allow precise control of motor speed and scheduling, so that you can achieve optimal pool system performance and maximum energy savings.

The SmartFlo utilizes Multi-Fit Unions and a Height Adjustable Base to maximize ease of installation. The pump has been designed to allow the height of the inlet to align with many popular pump models, and the unions allow acceptance of a broad range of plumbing options.

Model: USF1.7P		Model: USF2.0P		Model: USF3.0P	
HP	1.7HP	HP	2.0HP	HP	3.0HP
Input Voltage	230VAC	Input Voltage	230VAC	Input Voltage	230VAC
Input Current	0.1 - 7A	Input Current	0.1 - 8A	Input Current	0.1 - 10A
Energy Usage	17 - 1500 W	Energy Usage	17 - 1800 W	Energy Usage	18 - 2100 W
Speed Range	450 - 3450 RPM	Speed Range	450 - 3450 RPM	Speed Range	450 - 3450 RPM

INSTALLATION

Only a qualified individual should install the Variable Speed Pump. Refer to “Pump Warning And Safety Instructions” on pages 3-4 for additional installation and safety information.

Pump Configuration

The following configurations allow for maximum flexibility during setup:

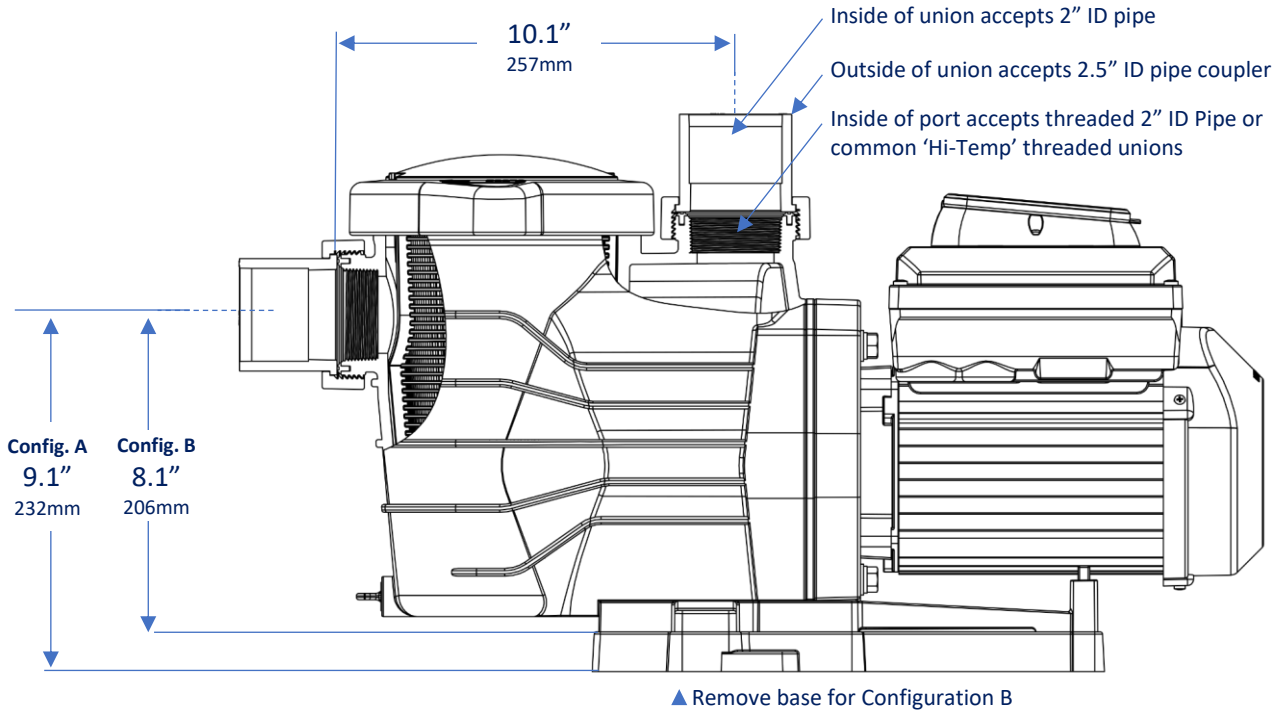

The SmartFlo pump unions and ports allow for easy connection to multiple plumbing sizes and methods:

- For 2.5" ID PVC piping, the outside of the pump unions will fit into couplers for 2.5" ID plumbing.
- For 2" ID PVC piping, the inside of the pump unions will allow insertion of pipe for 2" ID plumbing.
 - Alternatively, the inside of the pump ports have female threading that mates with threaded 2" PVC piping or commonly-available "Hi Temperature" pump unions. In this case, the included pump unions will not be utilized.
- For 1.5" ID PVC piping, use the included reducer bushings inside of the pump unions to allow the insertion of pipe for 1.5" ID plumbing.

The SmartFlo utilizes a height-adjustable base to allow close alignment with popular models from other manufacturers:

Configuration A: When the base is left in place, the suction and discharge ports will align closely with models such as Pentair® IntelliFlo® or Pentair® WhisperFlo VS/VST®, and the suction port will align closely with models such as Pentair® IntelliFlo XF® or Pentair® WhisperFlo XF®.

Configuration B: When the base is removed, the suction and discharge ports will align closely with models such as Hayward® Tristar® or Hayward® Ecostar®, and the suction port will align closely with models such as Hayward® Super II®.

Depending on which existing pump model plumbing you are attempting to match, achieving the closest alignment may require the use of one or the other: the female-threaded pump ports or the included pump unions.

Installation Location

Do not install this pump within an outer enclosure or beneath the skirt of a hot tub or spa unless marked accordingly. Airflow is required for motor.

Leave enough space for maintenance and service. Ensure that the pump is mechanically secured to the equipment pad.

Be sure pump location meets the following requirements:

- Install the pump as close to the pool or spa as possible. To reduce friction loss and improve efficiency, use short, direct suction and return piping.
- Install a minimum of 5 feet (1.52 meters) from the inside wall of the pool and spa. Canadian installations require a minimum of 9.8 feet (3 meters) from the inside wall of the pool.
- Install the pump a minimum of 3 feet (.9 meters) from the heater outlet.
- Do not install the pump more than 10 feet (3.1 meters) above the water level.
- Install the pump in a well-ventilated location protected from excess moisture (i.e. rain gutter downspouts, sprinklers, etc.).
- Install the pump with a top clearance of at least 12 inches (30.5 cm) so that the pump strainer basket can easily be removed. See **Figure 1**.
- Install the pump with a rear clearance of at least 3 inches (7.6 cm) so that the motor can be removed easily for maintenance and repair. See **Figure 1**.

Piping

Unionized pump ports also internally accept MIP-threaded PVC piping or high-heat pump unions. Be sure that suction & discharge ports are in an ideal position (see previous section “Pump Configuration”).

- For optimal pool plumbing efficiency, it is recommended to use a larger pipe size.
- Piping on the suction side of the pump should be the same or larger than the return line diameter.
- Plumbing on the suction side of the pump should be as short as possible.
- For most installations, installing a valve on both the pump suction and return lines allows that the pump to be isolated during routine maintenance. However, we also recommend that a valve, elbow or tee installed in the suction line should be no closer to the front of the pump than five (5) times the suction line diameter. See **Figure 2**.

Example: A 2.5 inch pipe requires a 12.5 inch (31.8 cm) straight run in front of the suction inlet of the pump. This will help the pump prime faster and last longer.

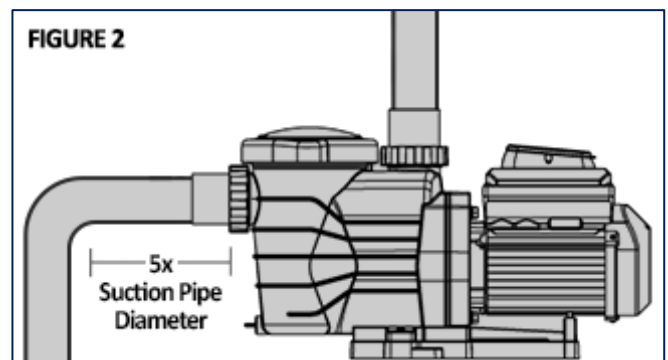
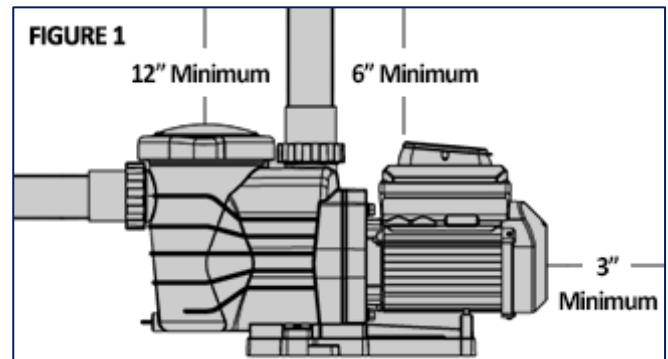

NOTE: DO NOT install 90° elbows directly into the pump inlet or outlet.

Fittings and Valves

- “Sweep” style elbows provide increased efficiency.
- Do not install 90° elbows directly into pump inlet.
- Flooded suction systems should have gate valves installed on suction and discharge pipes for maintenance, however, the suction gate valve should be no closer than five times the suction pipe diameter as described in this section.
- Use a check valve in the discharge line when using this pump for any application where there is significant height to the plumbing after the pump.
- Be sure to install check valves when plumbing in parallel with another pump. This helps prevent reverse rotation of the impeller and motor.

Electrical Requirements

- Install all equipment in accordance with the National Electrical code and all applicable local codes and ordinances.
- A means for disconnection must be incorporated in the fixed wiring in accordance with the wiring rules.

WARNING



RISK OF ELECTRICAL SHOCK OR ELECTROCUTION. The Variable Speed Pump must be installed by a qualified individual, service professional, or licensed or certified electrician in accordance with the National Electrical Code and all applicable local codes and ordinances. Improper installation will create an electrical hazard which could result in death or serious injury to users, installers, or others due to electrical shock, and may also cause damage to property.

Always disconnect power to the pump at the circuit breaker before servicing the pump. Failure to do so could result in death or serious injury to service people, pool users or others due to electric shock and/or property damage. Read all servicing instructions before working on the pump.

Wiring Overview and Installation

WARNING

Power should be turned off when installing, servicing, or repairing electrical components. Observe all warning notices posted on the existing equipment, pump, and in these installation instructions.

The pump must be wired according to the local electrical codes and standards. Always refer to the National Electrical Code®(NEC®). This pump should be installed by a licensed electrician.

The pump accepts 230V, 50 or 60Hz single phase input power. The terminal block connections are capable of handling up to 12AWG solid or stranded wire. There are also fast-on type quick connectors, however, check the local electrical codes for the desired connection method. The connections must be permanently made to the grounding terminal (see Figure 3) in the field wiring compartment according to the local electrical code.

The drive will operate on 2-phase Line-Line-Ground electrical systems as well as Line-Neutral-Ground systems. This pump must be permanently connected by a 15- or 20-amp circuit breaker as specified in the local electrical code.

1. Be sure all electrical breakers and switches are turned off before wiring motor. Always wait six (6) minutes after disconnecting the power from the pump before opening or servicing the drive.
2. Choose a wire size for the pump in accordance with the current National Electrical Code and all applicable local codes and ordinances. When in doubt use a heavier gauge (larger diameter) wire. Be sure the wiring voltage is within the operating range.
3. Be sure all electrical connections are clean and tight.
4. Cut wires to the appropriate length so they do not overlap or touch when connected to the terminal board.
5. Permanently ground the motor using the ground screw located on the inside rear of the controller interface (see Figure 3). Use the correct wire size and type specified by the current National Electrical Code. Be sure the ground wire is connected to an electrical service ground.
6. Bond the motor to all metal parts of the pool structure and to all electrical equipment, metal conduit and metal pipping within 5 feet (1.5 M) of the inside walls of the swimming pool, spa or hot tub in accordance with the current National Electrical Code. UL requires use of a solid copper bonding conductor not smaller than 8 AWG. See **Figure 3**. **NOTE:** For Canada, a 6 AWG or larger solid copper bonding conductor is required.
7. The pump should be permanently connected to either a circuit breaker, 2-pole timer or 2-pole relay. If AC power is supplied by a GFCI circuit breaker, use a dedicated circuit breaker that has no other electrical loads.
8. Connect the pump permanently to a circuit. Make sure no other lights or appliances are on the same.

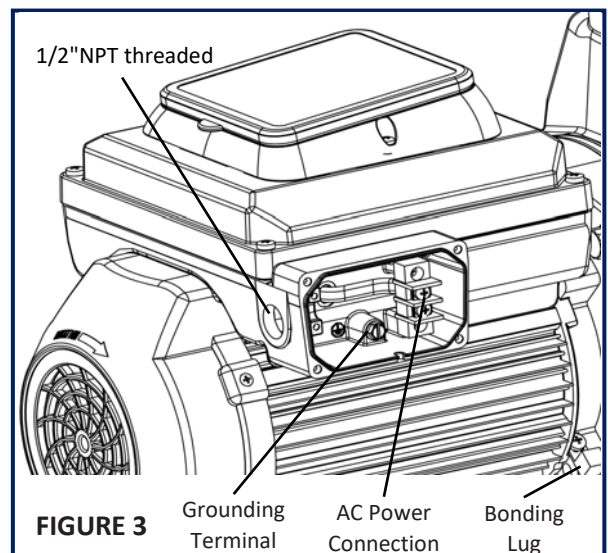

FIGURE 3

The field wiring compartment has a 1/2" NPT threaded conduit port for the liquid tight fitting.

The bonding lug should be used to bond the motor frame to the equipment pad.

CONTROL PANEL OVERVIEW



FIGURE 4



If power is connected to the Variable Speed Pump motor, pressing any of the following buttons referred to in this section could result in the motor starting. Failure to recognize this could result in personal injury or damage to equipment.

Keypad Navigation

- SPEED Buttons** - Use to select the desired run speed. The LED above the Speed Buttons will illuminate when that speed is selected or is currently running. A flashing LED indicates it is active on that speed's channel.
- MODE SELECT Button** - Use to set pump to Manual or Schedule-based operation.
- START / STOP Button** - Use to Start and Stop the pump. When the pump is stopped and the LED is not illuminated, the pump is unable to run from any type of input.
- Display Mode LED Indicators** - An illuminated LED indicates the information being displayed on the screen at any specific point. A flashing LED indicates that the parameter is currently being edited.
- MENU Display Button** - Use to toggle between the different available display modes. This button is also used to set the 24-hour clock and screen resolution.
- Quick Clean Button** – Use to run Quick Clean mode, a preprogrammed speed and duration set for temporary hi-flow activity (ex: vacuuming). When the LED is illuminated the Quick Clean schedule is active.
- < and > Arrow Buttons**- Choose between a 12 or 24 hour time format when programming.
- + and - Buttons** - Use to make on-screen adjustments to the pump settings. The + button increases the value of a given setting, while – decreases the value of a given setting. Pressing and holding down either button will increase or decrease the incremental changes faster.

OPERATING THE PUMP

Setting the Clock

When the pump is first installed, it is necessary to set the clock. Any daily schedule set by the user must be based on an accurate time setting.

To Set the Clock:

1. Before setting the clock, ensure that the pump has power but that its motor is stopped (press STAR/STOP if necessary).
2. To begin, press and hold < and > together for 3 seconds. The TIME LED light will begin to flash. Press the MENU button to enter the “Set Clock” mode. The TIME LED will be on solid.
 - NOTE: the TIME LED light will automatically begin flashing for 5 seconds when the pump is first turned on. You can also press MENU at this point to enter the “Set Clock” mode.
3. Use the < or > arrows to choose between a 12 or 24 hour time format.
4. Use the + or – buttons to change the displayed time to the correct time of day. In the 12 hour time format AM/PM will display in the bottom left corner.
5. To exit the clock setup mode, **press and hold the MENU button until the TIME light goes out.** The clock is now set.

If in Schedule mode, pressing START at this point will allow the pump to operate on the Default Schedule.

- NOTE: the pump will automatically begin to run the next time SPEED 1 is programmed to start. If desired, before this time you can press a SPEED button to manually run a preset speed/duration.

NOTE: During a power outage, the drive will retain the clock setting in memory for up to 24 hours. If the power is out longer than this time, the clock/program will have to be set again. When power is returned to the pump after a prolonged outage the clock will automatically set itself to the default Speed 1 start time, blink and advance. The pump will also run the associated schedule from that start time.

NOTE: When pump is used in sync with other timed devices, ensure that all time settings are updated if your area experiences daylight savings time changes.

Operation Overview

The pump has integrated electronics which control the speed settings as well as the run durations. The pump can operate at speeds ranging between 450 and 3450 RPM, allowing you to select the most appropriate speed for your application. For optimal use, the SmartFlo variable-speed pump is intended to run at the lowest speeds necessary in order to meet your pool’s needs of achieving sufficient pool circulation and maintaining a sanitary swimming pool environment. This can greatly minimize electricity consumption.



WARNING Depending on the pool system configuration, the specific pump speeds and run times may need to be adjusted to suit your pool’s needs. Whether using the Default Schedule or customized programming, **setup may require some trial-and-error to determine the most satisfactory settings as dictated by the conditions.** Upon initial setup, **ensure that all flow-dependent pool equipment is able to operate correctly at each chosen pump speed**, and that pool plumbing & equipment remains completely filled with water. Additionally, **ensure that the pump is not set so as to over-pressurize the pool system.** Continue to monitor the pool water and pool system during the first few days after initial setup, and make adjustments to the pump controller as needed.

Operation Overview (continued)

In most cases, setting the pump at the lower speeds for the longer durations is the best strategy to minimize energy consumption. However, conditions may require running the pump at a higher speed for some duration of time each day to maintain proper filtration and achieve satisfactory sanitation. The pool size, presence of additional water features, chemicals used to maintain sanitary conditions, and local environmental factors will impact optimal programming necessary to maximize energy conservation.

The general goal of a pool pump is to:

1. Circulate all of the water in the pool through the filter 1-2 times per day, called “turnovers”, and
2. Provide enough water flow for other flow-dependent pool equipment to function correctly.

Additionally, with a variable-speed pump the goal is to achieve this while using as little electricity as possible!

Typical example of variable-speed pump programmed operation:

FIGURE 5

graphics for example purposes only

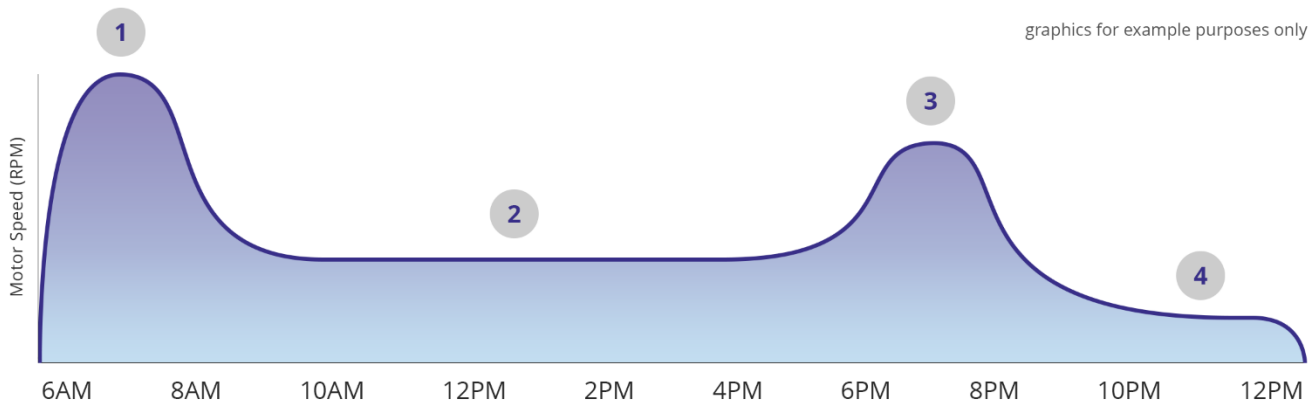

SPEED 1

High-speed ensures priming & allows forceful circulation to move heavier debris in pool to skimmer or drain

SPEED 2

Low-speed provides energy-efficient circulation and improved filtration by reducing filter pressure.

SPEED 3

You can schedule higher-speed operation to coincide with a booster-pump, water feature, etc...

SPEED 4

Lowest-speed circulation provides added filtration. Continual water movement can help prevent sediment build up.

Optimize the pump to suit individual pool conditions. Changes should be made on an as-needed basis, based on specific conditions including pool size, other devices, features and environmental factors which can all impact the optimal settings. For example, if a cleaner or water feature is scheduled to run at a certain time each day, coordinate the pump’s run times and speeds in order to provide higher flow sufficient for these devices. Another example, if local weather tends to regularly introduce vegetation debris or sediment into the pool at a certain part of the day, you can set the pump to higher speeds during or after this time to provide more forceful circulation that is better able to move heavier debris in the pool to the skimmer or drain; alternatively, you could consider more frequent alternating periods of higher and lower RPM’s to increase the number of times there is high circulation throughout the day while still aiming to minimize energy consumption and keeping the target of 1-2 turnovers in mind. An optimized pump program will be unique to your pool’s Total Dynamic Head (TDH), pool configuration, pool environment, pool use, and more.

Using the Default Schedule

The default schedule is designed to provide enough daily turnover to service a typical pool. See **Table 1** for default schedule. Be sure you have read Operation Overview warning on page 11.

	Duration	Speed (RPM)
SPEED 1	2	3000
SPEED 2	10	1500
SPEED 3	2	2500
SPEED 4	4	1000

Table 1: Default Schedule

How the Schedule Runs:

Using the Default Schedule as an example SPEED 1 is set to begin at 8:00am and run at 3000 RPM for a duration of 2 hours. When SPEED 1 is complete the pump immediately begins running the default SPEED 2. SPEED 2 is factory default to 1500 RPM and will last for 10 hours. When SPEED 2 has completed its run the pump will run SPEED 3 at 2500 RPM for a duration of two hours. When SPEED 3 has completed its run the pump will run SPEED 4 at 1000 RPM for a duration of four hours. After 18 hours of run time and completing its run of SPEED 4, the pump will enter a stationary/paused state for the next 6 hours. The pump will restart at 8:00am the next morning and cycle through the default schedule again. The pump will continue to run in this in this manner until a custom schedule is programmed into the drive by the user.

NOTE: The Start/Stop button must be pressed, and the LED lit, for the pump to run. **In Schedule mode, THE PUMP MOTOR WILL NOT AUTOMATICALLY BEGIN OPERATION until the beginning of its next scheduled cycle (the start time of Speed 1).**

Speed 1 and Priming

As mentioned, the specific pump speeds and run times may need to be adjusted to suit your pool's needs. This is especially important for the initial pump motor speed.

The installer should set the priming speed to be sufficient for priming the pump from a fresh install, but not so fast that there is a substantial waste of energy. The time the pump needs to achieve prime can change based on local environmental conditions such as water temperature, atmospheric pressure, and your pool's water level. All of

these things should be taken into consideration when setting the priming speed, however in most cases the pump will not need to run at 3450 RPM to successfully prime itself.

Please test and verify chosen priming speeds more than once, letting the water drain from the system in between each test. Turn on pump and switch to Manual mode to test Priming by operating SPEED1. Take note of the time that the water filled the PUMP HOUSING, then stop the pump. Re-start the pump to set the SPEED1/Priming duration. (For information about the priming process, please see "Priming the Pump" under "Restart Instructions" on page 18)

Custom Priming Speed (Optional)

In many cases (but not all), the higher motor speed setting desired for SPEED 1 will be sufficient to prime the pump. If due to local circumstances the required priming speed is significantly higher than the desired SPEED 1 setting, you can enable a Custom Priming Speed so that the pump does not have to run at this highest setting for the entire duration of SPEED 1. This feature is disabled by default; follow these instructions to set a Custom Priming Speed.

1. Ensure that the pump is stopped; if in operation, press the START/STOP button so that the LED above it is no longer lit.
2. Long-press the MENU button for about 5 seconds to enter the priming settings.
3. While in this menu, use the < and > arrows to cycle between options: Speed and Duration. The LED light will blink to indicate which option is being displayed.
4. The default priming speed is 3400 RPM. Use the + and – buttons to set your desired speed between 2000-3450 RPM.
5. The default duration for the custom priming speed is 0 minutes (indicating the feature is disabled). Use the + and – buttons to set the desired duration between 0-10 minutes.
6. Long-press the MENU button for 2 second to save these settings and exit this menu.

Custom Schedules and Quick Clean

To customize the run schedule for your Variable Speed Pump, the pump must be stopped. Be sure that the Start/Stop button LED is not illuminated.

Programming a Custom Schedule:

NOTE: When programming, the LED light next to the parameter you are setting ("Speed", "Time" or "Duration") will blink.

1. Stop the pump if it is running by pressing the Start/Stop button.
2. Press the "1" button. The LED above the selected SPEED will begin to blink and the "Speed" parameter LED will blink while editing. See Figure 76below.



Figure 6: Setting Speed

3. Use the "+" and "-" buttons to adjust the speed in RPM for SPEED 1. **NOTE:** Speed is adjusted up or down by increments of 10 RPM.
4. Press the "1" button again and the display will change to SPEED 1 start time. The "Time" parameter LED will begin to blink. This setting is the scheduled time that pump operation should begin. See Figure 7 below.



Figure 7: Setting Start Time

5. Use the "+" and "-" buttons to adjust the daily start time for SPEED 1.
6. Press the "1" button again and the display will change to SPEED 1 duration. The "Duration" parameter LED will begin to blink. See Figure 8 below.



Figure 8: Setting Duration

7. Use the "+" and "-" buttons to adjust the duration for SPEED 1 in hours and minutes. **NOTE:** The duration parameter is adjusted in 1 minute increments.
8. Pressing the "1" button will continue to cycle through these parameters, but the changes are immediately saved as they are adjusted.
9. Press the "2" button. The LED above SPEED 2 will begin to flash and the corresponding parameter LED will flash while editing.
10. Use the "+" and "-" buttons to adjust the speed in RPM for SPEED 2.
11. Press the "2" button again and the display will change to SPEED 2 duration. **NOTE:** SPEEDs 2, 3 and 4 do not have a start time, as they begin their duration immediately after the previous SPEED finishes.
12. Use the "+" and "-" buttons to adjust the duration for SPEED 2 in hours and minutes.
13. Repeat steps 9-12 to program SPEED 3-4 and QUICK CLEAN.

NOTE: Remember that the duration allowed for SPEED 3 will be limited to the remaining time in a 24 hour day. Any time in the 24 hour day not programmed into SPEEDs 1-4, the pump will remain in a stationary state.

$$[\text{SPEED 1} + \text{SPEED 2} + \text{SPEED 3} + \text{SPEED 4} < 24 \text{ Hours}]$$

14. Press the Start/Stop button and ensure the LED is lit. The pump is now on and will run the custom user-programmed schedule. **NOTE:** In Schedule mode, the pump motor will not automatically start running until the beginning of its next scheduled cycle (the start time of Speed 1)

Speed Priorities

Since 24 hours is the maximum number of hours in a day, the pump schedule will not allow durations exceeding this to be set. If the scheduled duration of any SPEED is changed so that the total programmed schedule would be over 24 hours, the length of subsequent SPEEDs will be shortened to compensate.

SPEEDS are prioritized as follows: SPEED 1 -> SPEED 2 -> SPEED 3 -> SPEED 4. SPEED 1 is the highest priority, while SPEED 4 is the lowest.

Example:

Starting Schedule (Before Adjustment)

SPEED 1 duration = 18 hours
SPEED 2 duration = 2 hours
SPEED 3 duration = 2 hours
SPEED 4 duration = 2 hours

If the user then reprograms SPEED 1 to run for 22 hours, SPEED 2 & 3 (lower priority speed) will automatically adjust to a 1 hour duration and SPEED 4 (lowest priority speed) will adjust to a 0 hour duration.

End Schedule (After Adjustment)

SPEED 1 duration = 22 hours
SPEED 2 duration = 1 hour
SPEED 3 duration = 1 hour
SPEED 4 duration = 0 hours

When the 24th hour of duration is programmed it will take time from the lower priority speeds in order to add them to the SPEED currently being adjusted.

Operating the Pump While Running



If power is connected to the pump motor, pressing any of the following buttons referred to in this section could result in the motor starting. Failure to recognize this could result in personal injury or damage to equipment.

When the pump motor is in operation, pressing the **MENU** button will cycle through the current parameters.

- **Speed** — current run speed
- **Time** — current time of day
- **Duration** — amount of time remaining at the current run speed
- **Watts** — amount of watts currently being consumed

Pressing any of the Speed Buttons (“1”, “2”, “3”, “4”, “Quick Clean”) while the pump is running will act as temporary override. It will run the speed and duration that is programmed for that button. Once completed it will default back to the appropriate point in the programmed schedule.

Customizing Freeze Protection

This pump comes equipped with an automatic freeze protection feature that will power-on the pump if surrounding air reaches the freeze protection temperature setting. The circuit provides continual, moderate flow through plumbing to help protect pool equipment. Please see “Winterizing” on page 16.

This feature is enabled by default. If needed, the Freeze Protection program settings can be customized:

1. Ensure that the pump is stopped; if in operation, press the START/STOP button so that the LED above it is no longer lit.
2. Press and hold both the + and - buttons for about 5 seconds to enter the priming settings.
3. While in this menu, use the < and > arrows to cycle between options: Speed, Duration, and Temperature. The LED light will blink to indicate which option is being displayed. **NOTE:** the LED for Watts represents Temperature in this menu.
4. The default speed for Freeze Protection is 1000 RPM. Use the + and – buttons to set your desired speed between 750-3450 RPM.
5. The duration for Freeze Protection represents the features being either enabled / disabled. The duration should remain set to 1:00 (enabled); the setting of 0:00 would disable the feature.
6. The default temperature for activation of the Freeze Protection feature is 40°F. This can be set between 40°-50°F. Press MODE here to switch between F and C.
7. Long-press the MENU button for 2 second to save these settings and exit this menu.

The freeze protection minimum activation temperature is 40°F due to the pump’s proximity to the warmer ground and its own latent/stored heat after running during the day. When the pump sensor detects temperatures in this range, it is often already near or below freezing in other areas of the pool equipment pad.

MAINTENANCE

⚠ WARNING

DO NOT open the strainer pot if Variable Speed Pump fails to prime or if pump has been operating without water in the strainer pot. Pumps operated in these circumstances may experience a build up of vapor pressure and may contain scalding hot water. Opening the pump may cause serious personal injury. In order to avoid the possibility of personal injury, make sure the suction and discharge valves are open and strainer pot temperature is cool to touch, then open with extreme caution.

⚠ CAUTION

To prevent damage to the pump and for proper operation of the system, clean pump strainer and skimmer baskets regularly.

Routine Maintenance

This pump is designed to require little-to-no service, just routine maintenance to keep the strainer basket clean. The basket which must be kept clean of leaves and debris at all times. View the basket through the clear lid to inspect for leaves and debris.

Regardless of the length of time between filter cleaning, it is most important to visually inspect the basket at least once a week.

Cleaning the Pump Strainer Basket

1. Press the **Start/Stop** button to stop the pump and turn off the pump at the circuit breaker.
2. Release pressure in the system.
3. Turn the lid in a counter-clockwise direction until it releases, lift lid off of pump.
4. Remove debris and rinse out the basket. Replace the basket if it is cracked.
5. Put the basket back into the housing. Be sure to align the notch in the bottom of the basket with the rib in the bottom of the volute.
6. Fill the pump pot and volute up to the inlet port with water.
7. Clean the cover, O-ring, and sealing surface of the pump pot. **NOTE:** It is important to keep the lid O-ring clean and well lubricated.
8. Reinstall the lid by placing the lid on the pot. Be sure the lid O-ring is properly placed. Seat the lid on the pump then turn clockwise until the handles are horizontal and lid fully mates to pump housing.
9. Ensure all valves have been returned to proper position. Turn the power on at the house circuit breaker. Ensure time clock is correct.
10. Open the manual air relief valve on top of the filter.
11. Stand clear of the filter. Start the pump.
12. Bleed air from the filter until a steady stream of water comes out. Close the manual air relief valve.

⚠ WARNING

THIS SYSTEM OPERATES UNDER HIGH PRESSURE. When any part of the circulating system (e.g., Lock Ring, Pump, Filter, Valves, etc.) is serviced, air can enter the system and become pressurized. Pressurized air can cause the lid to separate which can result in serious injury, death, or property damage. To avoid this potential hazard, follow above instructions.



Winterizing

You are responsible for determining when freezing conditions may occur. If freezing conditions are expected, take the following steps to reduce the risk of freeze damage. **Freeze damage is not covered under warranty.**

To prevent freeze damage, follow the procedures below:

1. Press the **Start/Stop** button to stop the pump and shut off electrical power for the pump at the circuit breaker.
2. Drain the water out of the pump housing by removing the two thumb-twist drain plugs from the housing. Store the plugs in the pump basket.
3. Cover the motor to protect it from severe rain, snow and ice.

NOTE: Do not wrap motor with plastic or other airtight materials during winter storage. The motor may be covered during a storm, winter storage, etc., but never when operating or expecting operation.

NOTE: In mild climate areas, when temporary freezing conditions may occur, run your filtering equipment all night to prevent freezing.

As a back-up, the SmartFlo has a built-in freeze protection mode to help ensure the water circulates when temperatures begin to get cold. If there is not already scheduled or manually set operation when surrounding temperatures get down to 40°F (default), the pump will begin to run continuously at 1000 RPM (default). The snowflake icon on the display will turn on.

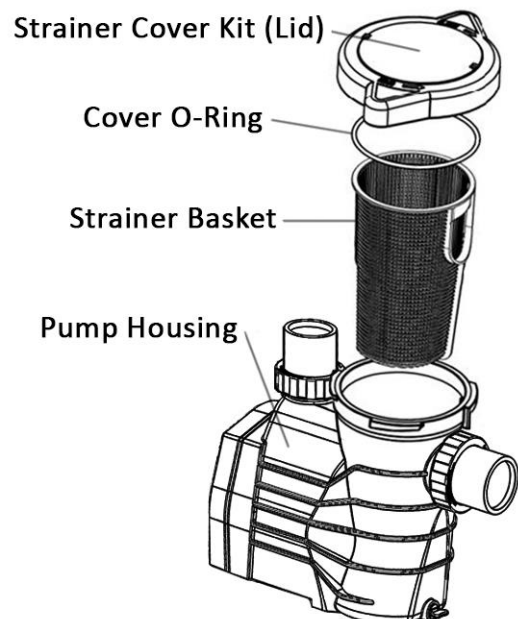

FIGURE 9: Strainer Pot



WARNING Always disconnect power to the Variable Speed Pump at the circuit breaker and disconnect the communication cable before servicing the pump. Failure to do so could result in death or serious injury to service people, users or others due to electric shock. Read all servicing instructions before working on the pump.



WARNING DO NOT open the strainer pot if pump fails to prime or if pump has been operating without water in the strainer pot. Pumps operated in these circumstances may experience a build up of vapor pressure and may contain scalding hot water. Opening the pump may cause serious personal injury. In order to avoid the possibility of personal injury, make sure the suction and discharge valves are open and strainer pot temperature is cool to touch, then open with extreme caution.



CAUTION Be sure not to scratch or mar the polished shaft seal faces; seal will leak if faces are damaged. The polished and lapped faces of the seal could be damaged if not handled with care.

Electric Motor Care

Protect from heat

1. Shade the motor from the sun.
2. Any enclosure must be well ventilated to prevent overheating.
3. Provide ample cross ventilation.

Protect against dirt

1. Protect from any foreign matter.
2. Do not store (or spill) chemicals on or near the motor.
3. Avoid sweeping or stirring up dust near the motor while it is operating.
4. If a motor has been damaged by dirt it may void the motor warranty.
5. Clean the lid and clamp, O-ring, and sealing surface of the pump pot.

Protect against moisture

1. Protect from splashing or sprayed water.
2. Protect from extreme weather such as flooding.
3. If motor internals have become wet - let them dry before operating. Do not allow the pump to operate if it has been flooded.
4. If a motor has been damaged by water it may void the motor warranty.

Shaft Seal Replacement

The Shaft Seal consists primarily of two parts, a rotating member and a ceramic seal.

The pump requires little or no service other than reasonable care, however a Shaft Seal may occasionally become damaged and must be replaced.

NOTE: The polished and lapped faces of the seal could be damaged if not handled with care.

Pump Disassembly

All moving parts are located in the rear sub-assembly of this pump. Tools required:

- 3/8 inch socket or open end wrench.
- Phillips screwdriver
- Flat blade screwdriver.

To remove and repair the motor subassembly, follow the steps below:

1. Press the Start/Stop button to stop the pump and turn off the pump circuit breaker at the main panel.
2. Drain the pump by removing the drain plugs.
3. Remove the 4 bolts that hold the main pump body (strainer pot/volute) to the rear sub-assembly.
4. GENTLY pull the two pump halves apart, removing the rear sub-assembly.
5. To unscrew the impeller from the shaft, insert a Phillips screwdriver into the hole of the motor fan and twist the impeller counter-clockwise. **See Figure 10**

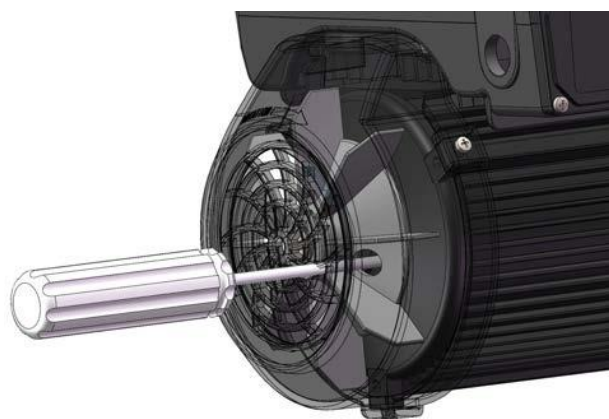

Figure 10

6. Place the seal plate face down on a flat surface and tap out the ceramic seal.
7. Remove the graphite seal ring on the impeller shaft.
8. Clean the seal plate, seal housing, and the impeller shaft.

CAUTION

DO NOT run the pump dry. If the pump is run dry, the mechanical seal will be damaged and the pump will start leaking. If this occurs, the damaged seal must be replaced. ALWAYS maintain proper water level. If the water level falls below the suction port, the pump will draw air through the suction port, losing the prime and causing the pump to run dry, resulting in a damaged seal. Continued operation in this manner could cause a loss of pressure, resulting in damage to the pump case, impeller and seal and may cause property damage and personal injury.

Damage due to operation of the pump while dry or without sufficient water is not covered by the warranty.

Pump Reassembly

1. When installing the replacement seal into the seal plate, use soapy water to wet the rubber boot before pressing it into the seal plate.
2. Remount the seal plate to the motor mounting plate.
3. Before installing the rotating part of the seal on the impeller shaft, wet the impeller shaft with soapy water and slide the seal to the impeller shaft end. Remove the dirt from the contact surface of the seal with a clean cloth.
4. Screw impeller onto the motor shaft (clockwise to tighten).

NOTE: Insert a Phillips screwdriver into the hole of the motor fan.

5. Remount the diffuser onto the seal plate.
6. Grease the diffuser quad ring and seal plate O-ring prior to reassembly.
7. Assemble the motor sub-assembly to the strainer pot-pump body. Tighten the bolts until all 4 bolts are in place and finger tightened.
8. Fill the pump with water.
9. Reinstall the pump lid and plastic clamp; see the next section, 'Restart Instructions'.
10. Re-prime the system.

Restart Instructions

If Variable Speed Pump is installed below the water level of the pool, close return and suction lines prior to opening hair and lint pot on pump. Make sure to re-open valves prior to operating.

Priming the Pump

The pump strainer pot must be filled with water before the pump is initially started.

Follow these steps to prime the pump:

1. Remove the pump lid.
2. Fill the pump strainer pot with water.
3. Reinstall the pump lid. The pump is now ready to prime.
4. Open the air release valve on the filter, and stand clear of the filter.
5. Turn on the power to the pump.
6. Press the **Start/Stop** button on the drive keypad. If the pump is currently scheduled to run it will start.
NOTE: If the pump is not scheduled to start, press **Speed 1** button to begin a manual override that will start the pump at its highest RPM's.
7. When water comes out of the air release valve, close the valve. The system should now be free of air and recirculating water to and from the pool.

FIGURE 11

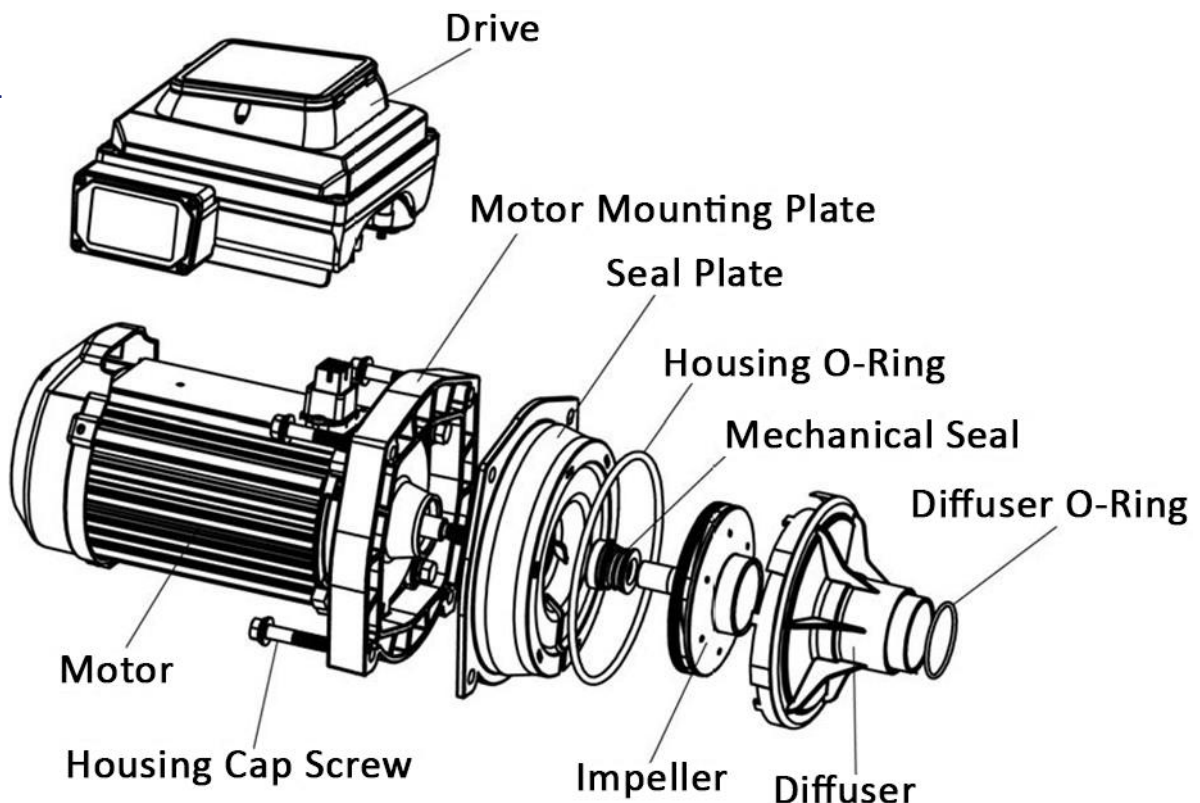

TROUBLESHOOTING



Diagnosing certain symptoms may require close interaction with, or in close proximity to, components that are energized with electricity. Contact with electricity can cause death, personal injury, or property damage. When trouble shooting the pump, diagnostics involving electricity should be cared for by a qualified individual.

SCENARIO:	POSSIBLE CAUSE:	SUGGESTED ACTION:
Pump Failure	Pump will not prime - Air leak, too much air.	Check suction piping and valve glands on any suction gate valves. Secure lid on pump strainer pot and be sure lid gasket is in place. Check water level to be sure skimmer is not drawing air.
	Pump will not prime - Not enough water.	Be sure the suction lines, pump, strainer, and pump volute are full of water. Be sure valve on suction line is working and open (some systems do not have valves). Check water level to make sure water is available through skimmer.
	Pump strainer basket is clogged.	Clean strainer basket and pump body.
	Pump lid o-ring missing or damaged	Replace o-ring.
Reduced capacity and/or head.	Air pockets or leaks in suction line.	Check suction piping and valve glands on any suction gate valves. Secure lid on pump strainer pot and be sure lid o-ring is in place. Check water level to be sure skimmer is not drawing air.
	Clogged impeller.	Turn off electrical power to the pump. Disassemble (see page 17, 'Pump Disassembly') Clean debris from impeller. If debris cannot be removed, complete the following steps: 1.Remove left hand thread anti-spin bolt & o-ring. 2.Remove, clean, and reinstall impeller. Reassemble (see page 18, 'Pump Reassembly')
	Pump strainer basket is clogged.	Clean strainer basket and pump body.
Pump fails to start.	Mains Voltage is not present	Check input power and all electrical switches / breaker / GFCI, check mains wiring and connection at motor terminals.
	Pump shaft is locked	Check if the pump can be rotated by hand and remove any blockage.
	Pump shaft is damaged	Replace the motor or the bearing.
Pump runs then stops.	Module overheating (error code E-14)	Check that back of pump is free from dirt and debris. Use compressed air to clean.
	Other error code displayed	Check error codes on next page.
Pump is noisy.	Debris in contact with fan	Check that back of pump is free from dirt and debris. Use compressed air to clean.
	Debris in strainer basket	Clean strainer basket.
	Loose mounting	Check that pump's mounting bolts and pump are tight.
	Debris inside impeller	Clean strainer basket, pump body, and impeller.
	Pump shaft is damaged	Replaced damaged part(s), motor or bearings.
Pump runs without flow.	Impeller is loose	Check that pump is spinning by looking at fan on back of Variable Speed Pump. If so, check that pump impeller is correctly installed.
	Air leak	Check plumbing connections and verify they are tight.
	Clogged or restricted plumbing	Check for blockage in strainer or suction side piping. Checked for blockage in discharge piping including partially closed valve or dirty pool filter.

For more information or troubleshooting, visit www.circupool.com/help

Errors and Alarms

If an fault is detected, the screen will display the error code text and the Variable Speed Pump will stop running. Disconnect power to the pump and wait until the keypad LEDs have all turned off. At this point, reconnect power to the pump. If the error has not cleared, then troubleshooting will be required. Use the error description table below to begin troubleshooting.

Error Code	Description	Error Code	Description
E-01	Inverter unit protection	E-11	Phase loss at input side
E-02	Acceleration over current	E-12	Phase failure at output side
E-03	Deceleration over current	E-14	Module overheating
E-04	Constant speed over current	E-16	Communication fault
E-05	Acceleration over voltage	E-17	Current detection fault
E-06	Deceleration over voltage	E-24	Inverter hardware fault
E-07	Constant speed over voltage		
E-08	Under voltage fault		
E-09	Motor overload		
E-10	Inverter overload		

E-08 - Absolute AC Under Voltage Detected: This indicates that the supply voltage has dropped below the operating range of 200v. This could be caused by normal voltage variation and will clear itself. Otherwise there could be excess voltage sag caused by improper installation or improper supply voltage.

E-14 - Module Overheating: This error may be caused by high ambient temperature (over 104° F) or overloading. Check that fan blade cover and ensure that it is not blocked, and that the fan blade is free and undamaged.

E-16 - Communication Link between the HMI and Motor control has been lost: Check the jacketed wire on the back side of the keypad inside the drive top cover. Ensure that the 6-pin connector is properly plugged into the socket and that there is no damage to the cable.

E-01,02,03,04,05,06,07,09,10,24 – Internal Errors: If this error displays multiple times, then there may be a problem with the pump’s rotating assembly. Please disassemble the pump and investigate to see if there is a problem with the impeller or mechanical seal, or bearings. See page 17 “Pump Disassembly” for instructions for disassembling the pump.

REPLACEMENT PARTS

SmartFlo Replacement Parts List

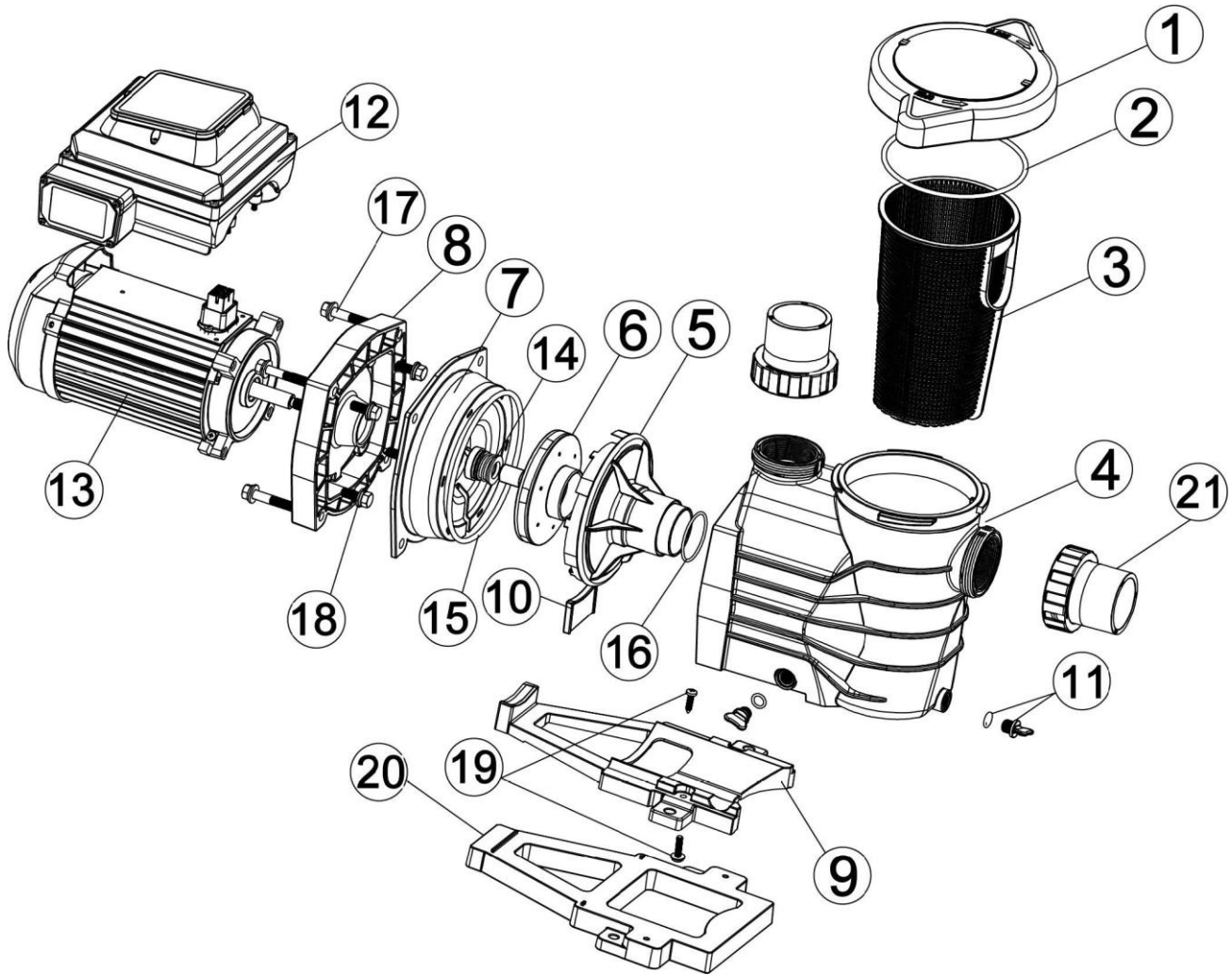

Ref. No.	Part No.	Description	Qty.
1	SF1.0P-SCK	Strainer cover Kit	1
2	SF1.0P-CO	Cover o-ring	1
3	SF1.0P-B	Strainer Basket	1
4	USF1.0P-PH	2" x 2" Pump housing	1
5	SF1.0P-D	Diffuser	1
6A	SF1.0P-IA	Impeller for SF1.0P, SF1.5H	1
6B	SF1.5P-IA	Impeller for SF1.5P	1
6C	SF2.0P-IA	Impeller for SF2.0P	1
6D	SF3.0P-IA	Impeller for SF3.0P	1
7	SF1.0P-SP	Seal Plate	1
8	SF1.0P-MP	Mounting Plate	1
9	SF1.0P-MF	Mounting Foot	1
10	SF1.0P-SF	Supporting Foot	1
11	SF1.0P-DPG	Drain Plug with Gasket	2
12A	SF1.0P-MD	Motor USF1.0P	1

Ref. No.	Part No.	Description	Qty.
12B	SF1.5P-MD	Motor Drive for USF1.7P	1
12C	SF2.0P-MD	Motor Drive for USF2.0P	1
12D	SF3.0P-MD	Motor Drive for USF3.0P	1
13A	SF1.0P-M	Motor USF1.0P	1
13B	SF1.5P-M	Motor USF1.7P	1
13C	SF2.0P-M	Motor USF2.0P	1
13D	SF3.0P-M	Motor USF3.0P	1
14	SF1.0P-SA	Seal Assembly	1
15	SF1.0P-SPO	Seal Plate o-ring	1
16	SF1.0P-DO	Diffuser o-ring	1
17	SF1.0P-HCS	Housing Cap Screw 3/8-16*2	4
18	SF1.0P-MCS	Motor Cap Screws 3/8-16*1	4
19	SF1.0P-MPS	Mounting Foot Screws	2
20	USF1.0P-B	Base	1
21	SF1.0P-UCK	Union Connector Kit	2

Specifications

Model USF1.0P, USF1.7P, USF2.0P, USF3.0P

Overall Ratings				
Model	USF1.0P	USF1.7P	USF2.0P	USF3.0P
Input Voltage	230 V			
Input Frequency	Single phase, 50 or 60 Hz			
Input Current	5.5A	7A	8A	10A
Max Continuous Load	1HP	1.7HP	2HP	3HP
Speed Range	450 – 3450 RPM			
Environmental Rating	NEMA Type 3			
Port Size	2" x 2" - accepts 2" MIP threaded pipe or threaded high-heat unions (recommended)			

Pump Dimensions

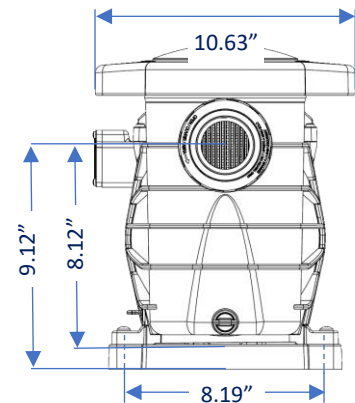
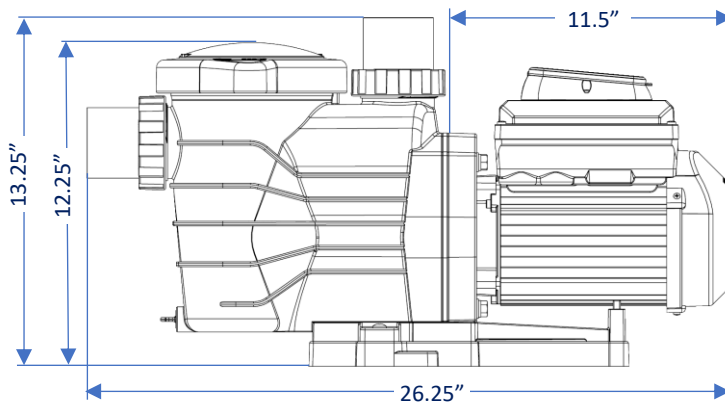

Performance Curves

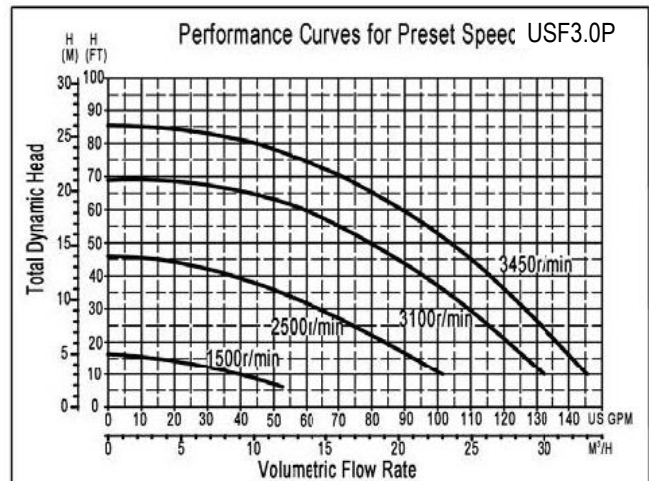
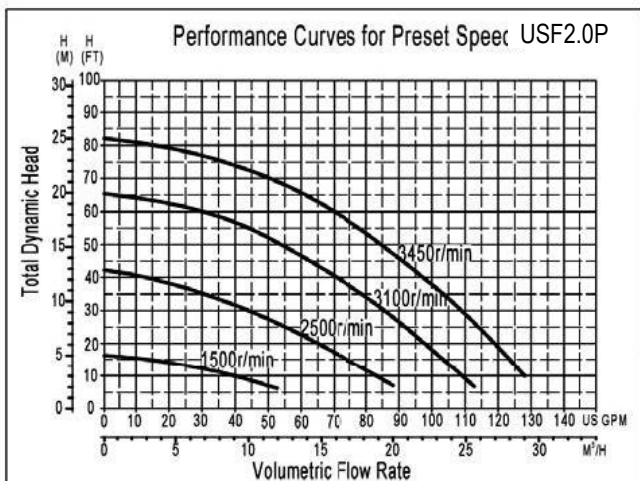
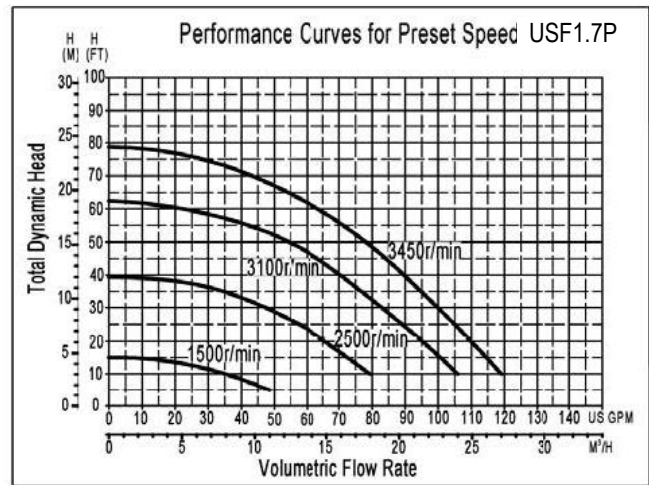
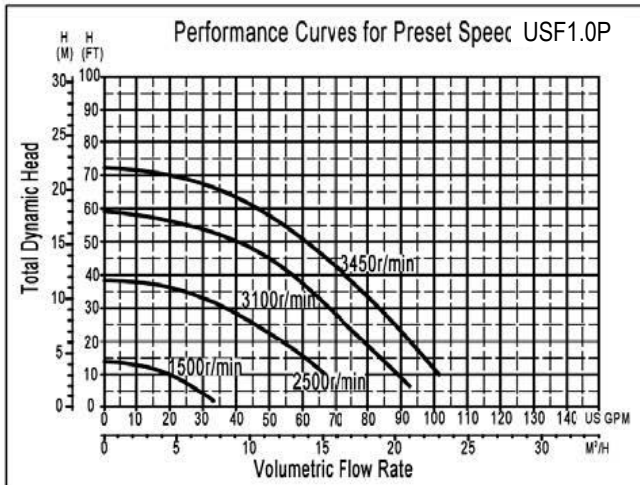

CIRCUPOOL LIMITED WARRANTY

CircuPool SmartFlo Series Variable Speed Pumps carry the following Limited Warranty should failure occur due to faulty manufacture or materials, during normal use and service. For residential use, the manufacturer warrants to the original purchaser that the equipment shall be free of manufacturer's defects at the time of sale, and upon examination shall provide replacement parts in accordance with the following schedule: 5 Years Pump Body / 1 Year Motor.

For Commercial use (any pool that is not for private single-family use, or the use of which is subject to regulation), parts are warranted against defect for a period of one year.

This limited warranty is subject to the following terms, conditions, and exclusions:

1. To obtain the benefits of this warranty, contact the warranty department for troubleshooting. You may obtain current contact information at www.circupool.com/help. Warranty claims must be initiated in a timely manner. Upon discovery of a defect, the warranty department will issue a Return Merchandise Authorization (RMA) and defective items and parts are to be shipped by customer to an authorized service representative, freight prepaid.

Upon examination, the determination of the cause of failure shall be made solely by CircuPool Products. The date upon which the claim is submitted, and an RMA is issued shall solely serve to determine at what point the claim falls within the schedule of warranty proration, in comparison with the original purchase date. **No packages will be accepted without a RMA number.**

2. Should a defect in any item or part covered by the warranty become evident during the warranty's term, CircuPool Products will at its sole discretion repair or replace such item or part. CircuPool Products reserves the right to replace defective parts with new or refurbished parts. This warranty does not include the cost of labor or transportation charges for equipment or component parts to or from CircuPool Products, or the removal, reinstallation, or any such costs incurred in obtaining warranty replacements or repair.

3. This warranty extends to the original retail purchaser and original installation site only, beginning at the original date of purchase, and is non-transferrable.

4. The warranty contains the following exclusions. O-Rings, rubber gaskets and seals, electrical fuses, and circuit-breaker components are normal replacement items subject to wear and are excluded from the warranty. Product discoloration, or any other cosmetic or superficial damage or deterioration, regardless of its cause, is not covered by this warranty. The warranty is not applicable to problems arising from circumstances outside the control of CircuPool Products, including, but not limited to the following:

- A. Damage or premature wear due to improper pool chemistry, and failure to maintain pool water chemistry in accordance with the recommendations contained in the owner's manual.
- B. Damage due to improper installation or connection to improper voltages, including materials and workmanship supplied by others.
- C. Damage due to negligence or failure to properly maintain equipment, including operation with insufficient water flow or the maintenance of clean and tight electrical connections.
- D. Damage due to improper service, as well as unauthorized equipment modifications and use of non-genuine replacement parts.
- E. Damage due to misapplication, improper sizing, misuse, abuse, or failure to operate equipment as specified in the owner's manual and overuse.
- F. Problems resulting from tampering, accident, fire, flood, freezing, lightning, insects, or other natural elements, or other circumstances beyond the control of CircuPool Products.
- G. Damage due to over-tightening of threaded components or excessive pressure or stress.

The liability of CircuPool Products shall not exceed the repair or replacement of defective items or parts under the referenced limited warranty terms. There are no implied warranties of merchantability or fitness for a particular purpose that apply to this equipment. Under no circumstances shall CircuPool Products, its agents, employees, and affiliates be liable for any loss, damage, injury, inconvenience or loss of time, incidental expenses such as labor and material charges, or any other incidental, special, or consequential damages, which may result from the use, installation, removal, or reinstallation of its equipment and parts.

Disclaimer: This limited warranty is the entire warranty. No other warranties apply, expressed or implied. This warranty is valid only in the United States of America. This warranty gives you specific legal rights and you may also have other rights, which vary from state to state. This warranty supersedes all previous publications. Any dispute between the original purchaser and CircuPool Products will be settled by binding arbitration, conducted in Harris County, Texas, under the rules of the American Arbitration Association.

